

ADB-S2

High-speed Drill, Point and Broach Machine



Key Points

- Drilling, Pointing, Facing and Broaching of aerospace fasteners
- Output approximately 3,000 parts per hour
- 2 rotating spindles with independent servo-controlled feed and speed
- Servo-controlled broaching
- Fast changeover with pre-set tooling
- Specially-written user-friendly software in multiple languages
- 3G / Ethernet Modem for remote access
- Industry 4.0 compatible

Application

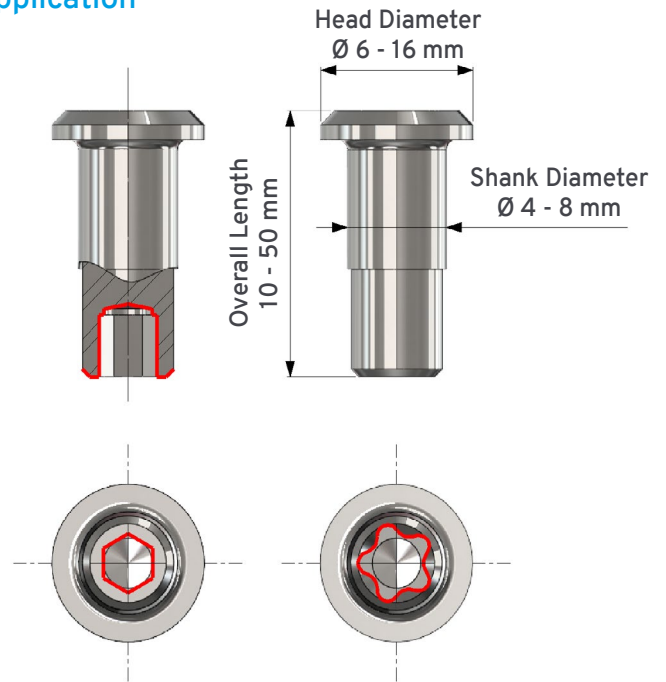

Features

- 450 mm (18") Vibratory Bowl Feeder.
- 3 Stations
 - W-Tool (Centre-Drill, Point & Face)
 - Drill
 - Broach.
- 0 - 5000 rpm spindle speed
- Servo-controlled Broach producing up to 1.8 tonnes (4,000 lbs) broaching force
- Quick-change pre-settable HSK-32 Toolholders
- Quick-change Clamping Cassettes
- Automatic tool breakage detectors

View product at e-tech.co.uk

or contact sales@e-tech.co.uk