

# FR-FX5

## Flexible Automatic Fillet Rolling Machine



### Key Points

- Rolling the underhead radius
- 800 - 1500 parts per hour depending on size
- Precise, programmable rolling parameters with 100% in-process checking.
- Fast changeover
- Safe, clean working and easy maintenance
- Specially-written user-friendly software in multiple languages
- 3G / Ethernet Modem for remote access
- Industry 4.0 compatible

### Application

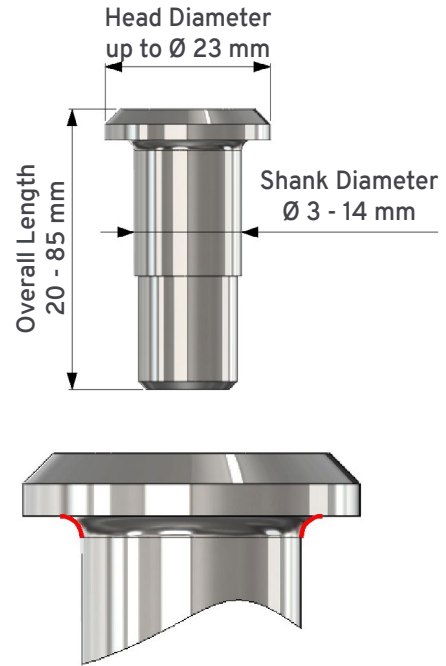

### Features

- Load cell to measure actual rolling force during each cycle and to check that it is within programmed limits
- Programmable control of rolling force, rpm & time
- Pneumatic cylinder producing up to 1,000kg rolling force
- Drive unit with inverter controlled spindle motor
- 18" dia (450 mm) Vibratory Bowl Feeder
- 'Air-mover' system to deliver parts into machine
- Fast pneumatically-actuated loading system
- Allen Bradley or Siemens PLC control system with 6" touch-screen (HMI)
- Integrated coolant tank, filter and pump

View product at [e-tech.co.uk](http://e-tech.co.uk)

or contact [sales@e-tech.co.uk](mailto:sales@e-tech.co.uk)