



Play Film



Play Options

# VSG-M2L Valve Seat Grinding Machine

## Large/Truck Valves

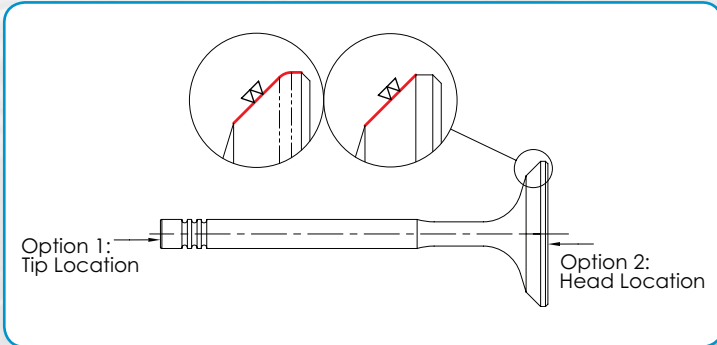

### Key Points

- Cycle Time: 5 to 8 seconds
- Programmable servo-controlled loading system
- Programmable servo-controlled unloading system
- Very fast set up and changeover
- Soft handling of parts

### Features

- 6 servo axes
- 4500 RPM grinding spindle
- 600mm Ø or 500mm Ø grinding wheel
- Schmitt wheel balancer integrated into grinding spindle
- Static diamond dresser or 6000 rpm rotary disc dresser
- SMC or Festo pneumatics
- Multiple languages
- Kraft & Bauer fire suppression system
- Optional programmable servo-controlled unloading system

### Valve Size Range

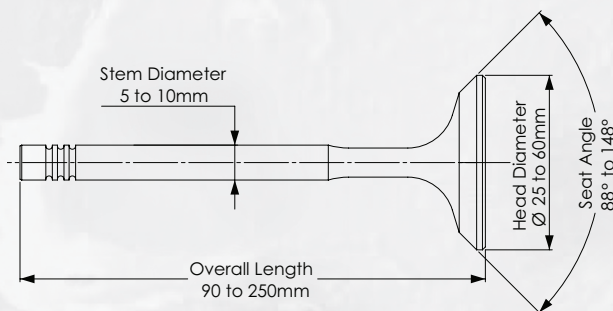

NOTE : All measurements are for a standard machine. Other options are available.

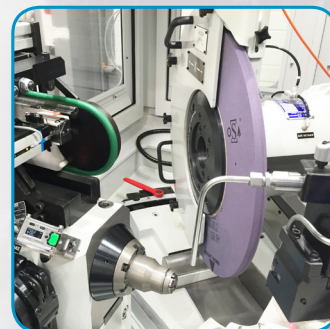
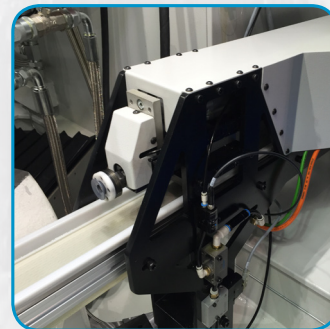

### Capability

PpK values > 1.67 for drawing tolerances of:

- Seat Datum to Top of Head: +/- 0.050 mm
- Seat Datum to Tip: +/- 0.050 mm
- Seat Run-out (TIR): 0.030 mm
- Seat Roundness: 0.005 mm
- Seat Finish: 0.4 microns Ra