

ADB-L2

Automatic Drill, Point and Broach Machine



Key Points

- Drilling, pointing, facing and broaching with petal removal
- 1000 – 1500 parts per hour
- All spindles have servo motor drive and servo in-feed
- Broaching with servo-controlled roller screw
- Servo-controlled indexing
- No hydraulics
- Specially-written user-friendly software in multiple languages
- 3G / Ethernet Modem for remote access
- Industry 4.0 compatible

Application

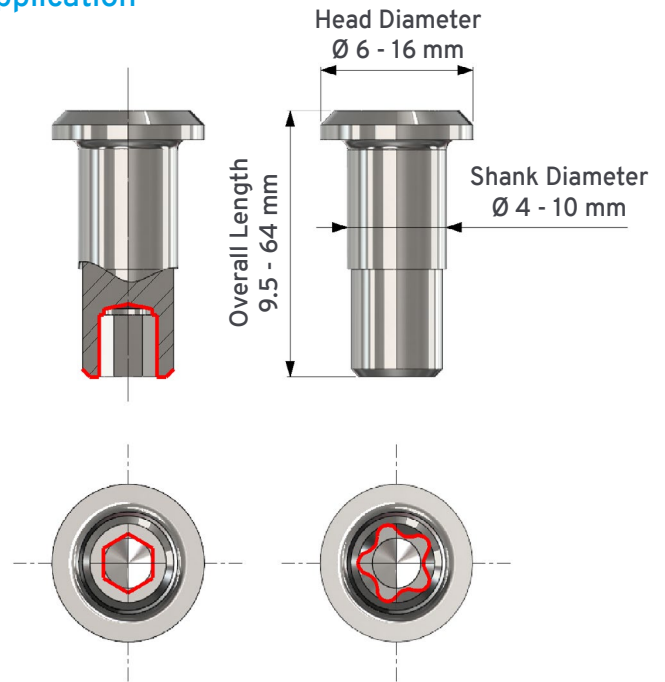

Features

- Stations:
 1. Load
 2. Centre Drill
 3. Drill
 4. 2nd Drill
 5. Point & face
 6. 2,000kgf Servo-controlled broach
 7. Drill petals
 8. Air blast to remove petals
 9. Coolant wash to clean locations
 10. Eject
- Full programmable control of all axes
- Independent control of all cutting speed and feeds
- Pre-settable tool-holders

View product at e-tech.co.uk

or contact sales@e-tech.co.uk