

FR-V3

High-speed Fillet Rolling Machine
- With Tube Loading



Key Points

- 2 roller machine
- Output up to 3,600 parts per hour
- 100% in-process control of quality
- 100% Monitoring of Rolling Force, Rolling Time and Roller Rotation
- Fully Programmable
- Minimal coolant use. No coolant splash or mist
- Very small footprint (Approximately 1m x 1m (3' x 3'))
- Fast changeover
- Gives your customers 100% confidence

Application

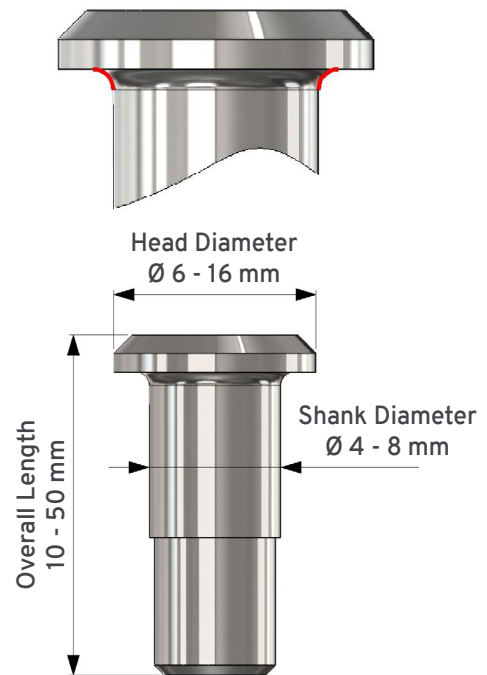

Features

- 15"/ 350 mm Ø Vibratory Bowl Feeder
- Up to 400 kgf / 880 lbf Rolling Force
- Load cell integrated into spindle to measure actual rolling force
- Programmable control of rolling force, rpm and time
- Servo controlled spindle motor
- Allen Bradley or Siemens PLC control system with touch-screen HMI
- 3G / Ethernet modem for remote access
- Integrated coolant tank, filter and pump
- Lockable tool tray

View product at e-tech.co.uk

or contact sales@e-tech.co.uk