

Key Points

- Cycle Time: 3.5 to 5 seconds
- Programmable servo-controlled loading system
- Very fast set up and changeover
- Soft handling of parts

Features

- 5 servo axes
- 4500 RPM grinding spindle
- 600mm Ø or 500mm Ø grinding wheel
- Schmitt wheel balancer integrated into grinding spindle
- Static diamond dresser or 6000 rpm rotary disc dresser
- SMC or Festo pneumatics
- Multiple languages
- Kraft & Bauer fire suppression system
- Optional programmable servo-controlled unloading system
- Optional High-pressure Wheel Cleaning System with servo control

Capability

PpK values > 1.67 for drawing tolerances of:

Seat Datum to Top of Head	+/- 0.040 mm
Seat Datum to Tip:	+/- 0.040 mm
Seat Run-out (TIR):	0.030 mm
Seat Roundness:	0.005 mm
Seat Finish:	0.4 microns Ra

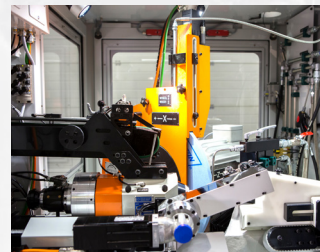
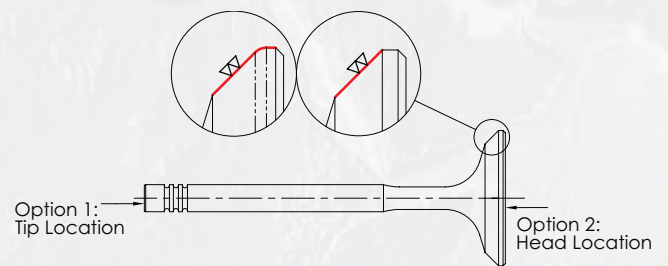

Valve Size Range

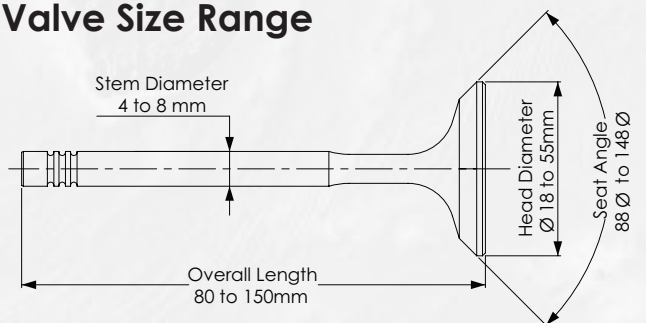

Note: All measurements are for a standard machine. Other options are available.