

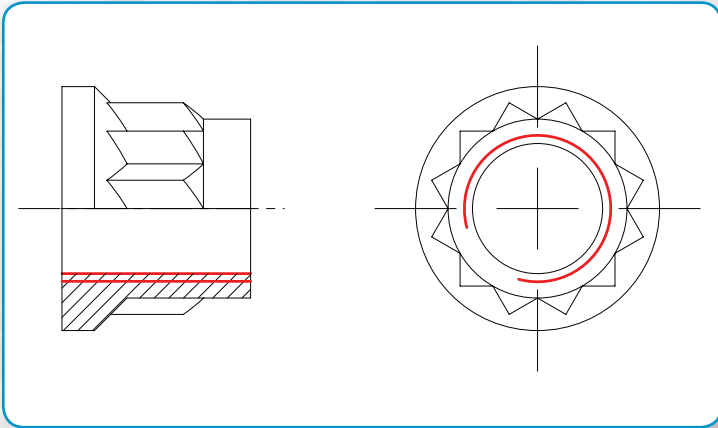

# RT-TX1 Drilling, Reaming & Tapping Machine



## Key Points

- Fast changeover
- Servo controlled tapping heads
- Change thread pitches with a touch of a button
- Safe, clean working
- Ease of maintenance
- Giving your customers 100% confidence

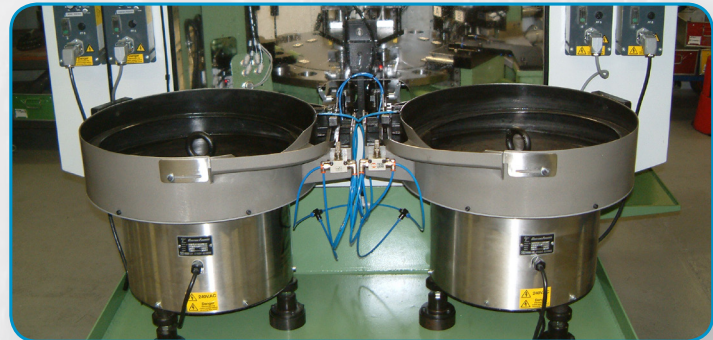

## Features

- Reaming and tapping 2 different nut sizes simultaneously
- Production rates up to 24 parts per minute.
- Customised touch-screen operator control.
- Tool wear monitoring by measurement of spindle current
- Quick Changeover
- Automatic removal of swarf from parts
- Allen Bradley or Siemens PLC control system with 6" touch-screen (HMI)
- Lockable tool tray
- 6 stations x 2
  - Load
  - Ream
  - Tap
  - Spare Station for Changing Tooling
  - Clear Swarf and Unload
  - Automatic Cleaning of Tooling

