

HTD-X3

Head Turning and Drilling Machine

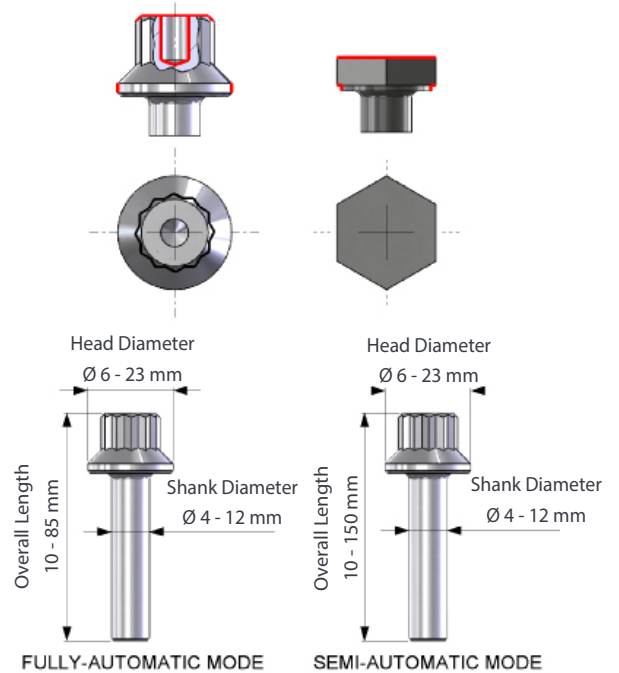

Application



Key Points

- Head turn and drill on one machine
- Facing and chamfering
- Drilling of axial holes
- Easy maintenance
- Industry 4.0 compatible

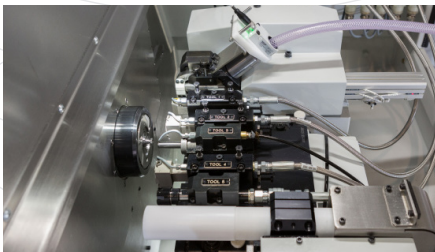

Features

- Siemens SINUMERIK ONE CNC control
- Easy to learn customised graphical interface
- Heidenhain linear encoders on X and Z axes
- Fast pneumatic loading system
- 5-station gang tooling plate
- Tools with standard indexable inserts
- Pre-settable drill holders
- Integrated swarf conveyor
- Automatic crash detection system
- Specially-written user-friendly software in multiple languages

 View product at e-tech.co.uk

 or contact sales@e-tech.co.uk